



S-TEC

MAGIC[®]

Cessna Citation

500/501, 550/551, S550, 560/552, and Eagle II Engine Instrument Display System

Pilot's Operating Handbook

EDU P/N: 84-142-1 or Equivalent

DAU P/N: 85-267-1 or Equivalent



S-TEC
One S-TEC Way
Municipal Airport
Mineral Wells
TX 76067-9236
USA

Tel: +1(940) 325 9406
Toll-free: +1(800) 872 7832
Fax: +1 (940) 325 3904

www.s-tec.com
www.meggitt.com

MEGGITT

Page Intentionally Blank

Table of Contents

<u>Section</u>	<u>Page</u>
1.0 Overview.....	1-3
2.0 Engine Display Unit (EDU) Operation.....	2-3
3.0 Pre-Flight Test Procedure.....	3-3
4.0 Appendices.....	4-3
5.0 Glossary.....	5-3

List of Figures

<u>Figure</u>	<u>Page</u>
1-1 Primary Engine Display Unit (EDU).....	1-4
1-2 Secondary Engine Display Unit (EDU).....	1-5
1-3 EIDS System Block Diagram.....	1-6
1-4 Primary Engine Display Unit (EDU) (Displayed Data).....	1-7
1-5 Secondary Engine Display Unit (EDU) (Displayed Data).....	1-8
1-6 Reversionary Display (Displayed Data).....	1-9
2-1 Initialization Pages.....	2-3
2-2 Exceedance Data Display.....	2-5
2-3 Flowchart of Page Sequencing, Primary/Secondary Modes.....	2-6
2-4 Primary Engine Display Unit.....	2-7
2-5 Secondary Engine Display Secondary Page.....	2-7
2-6 Reversionary Display Page.....	2-8
2-7 PAGE Pushbutton Operation - Test Mode.....	2-10
2-8 EDU Data Page.....	2-11
2-9 FQP Data Page	2-12
2-10 DAU Data Page	2-13

List of Tables

<u>Table</u>	<u>Page</u>
2-1 Test Mode Pages.....	2-9
2-2 Annunciations.....	2-14

Notice: This handbook must be used in conjunction with the Federal Aviation Administration (FAA) approved Aircraft Flight Manual (AFM) or Aircraft Flight Manual Supplement (AFMS). Refer to the applicable AFM or AFMS for aircraft specific information, aircraft emergency procedures, and return of aircraft to service.

Page Intentionally Blank

SECTION 1 OVERVIEW

Page Intentionally Blank

1.0 Overview

This document provides operating instructions for the Meggitt Avionics (MAv) MAGIC® Engine Instrument Display System (EIDS).

1.1 Equipment Description

The **MAGIC® EIDS** is a technologically advanced display and sensor system that provides accurate indications of engine parameters, fuel quantity, and fuel used computations for presentation on Active Matrix Liquid Crystal Displays (**AMLCD**).

1.1.1 Engine Display Unit (EDU)

The Engine Display Unit is a microprocessor-based display system. The system will accept aircraft sensor data for two engines via serial data bus interfaces, then present this information on an Active Matrix Liquid Crystal Display. The **EDU** supports four **ARINC 429**, two **RS-422** and one **RS-232** serial data busses.

Information is conveyed to the flight-deck via a series of predefined display formats as shown in Fig. 1-1 and Fig. 1-2. These data include engine parameters, fuel quantity, as well as, other aircraft status / information (see Fig. 1-1).

In addition, the **EDU** includes built-in test and display brightness controls. **PAGE** selection and **MAINT** are commanded via front bezel-mounted pushbuttons. Brightness is controlled via a front bezel-mounted, rotatable knob.

Primary EDU

- ITT
- N1%
- N2%

Secondary EDU

- L/R OIL TEMP
- L/R FUEL QTY
- TOTAL FUEL QTY
- L/R FUEL FLOW
- L/R VIB
- L/R BYP
- L/R IDL
- L/R MAN
- L/R OIL PRESSURE
- ENDURANCE

NOTE: Both EDU's are capable of displaying all engine parameters on one screen in Revisionary Mode. In Reversionary Mode, Fuel Used data is not present.

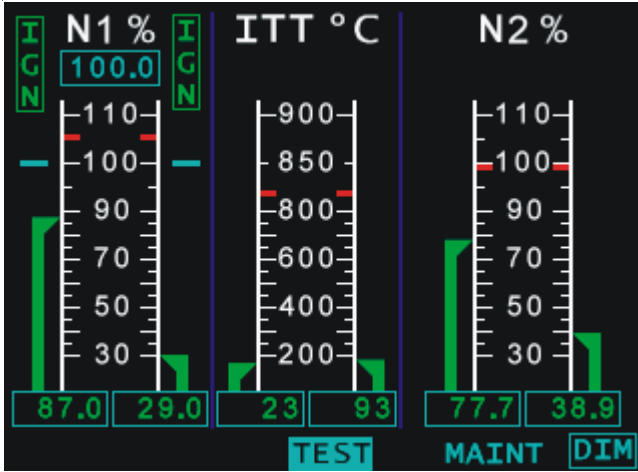

Fig. 1-1. Primary Engine Display Unit (EDU)

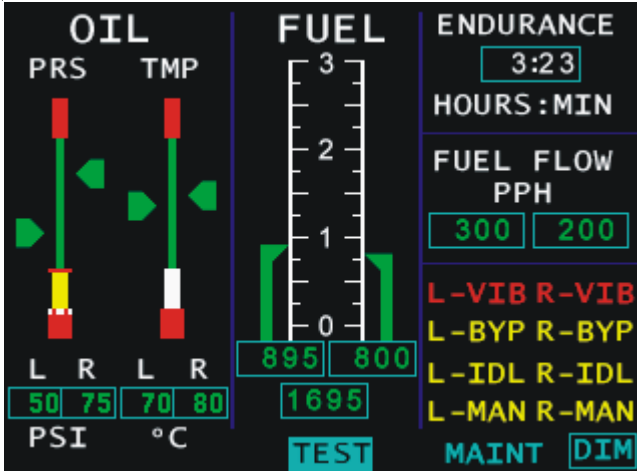

Fig. 1-2. Secondary Engine Display Unit (EDU)

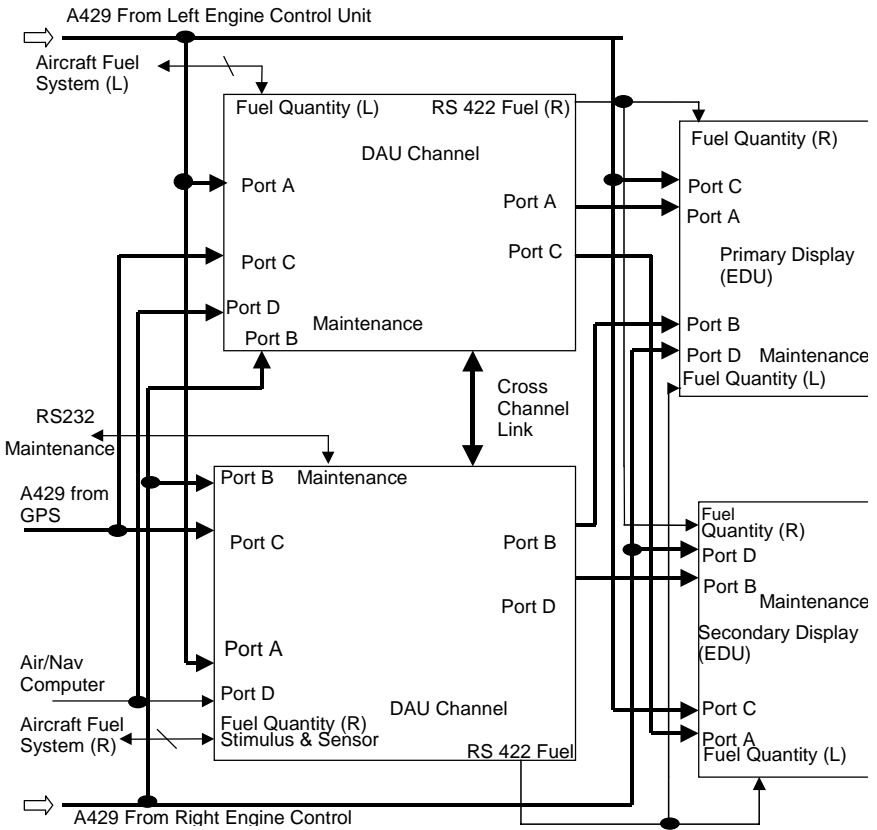

Fig. 1-3. EIDS System Block Diagram

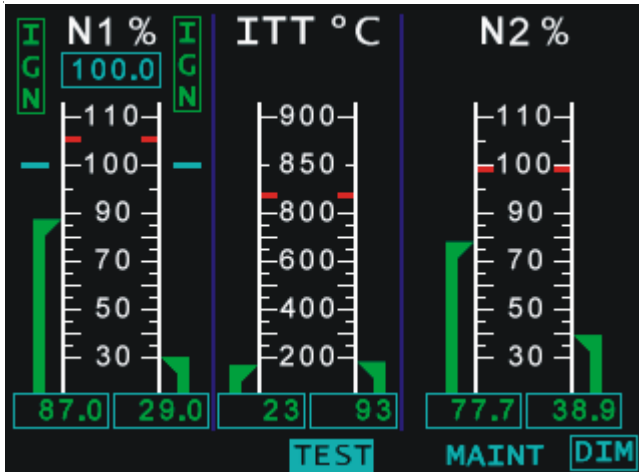

Fig. 1-4. Primary Engine Display Unit (EDU)

The information presented in the Primary page includes:

- **ITT** - Inter Turbine Temperature in degrees Celsius.
- **N1%** - The **N1** rotational rate, expressed as a percentage of maximum.
- **N2%** - The **N2** rotational rate, expressed as a percentage of maximum.
- **IGN** - The **IGN** indicator is displayed when the left or right engine igniter is on. (N/A for Eagle II, optional on other modified aircraft).
- **MAINT** - The **MAINT** indicator is illuminated when a maintenance action is required.
- **DIM/N1** - Indicates the current mode of the **SET** rotary knob.

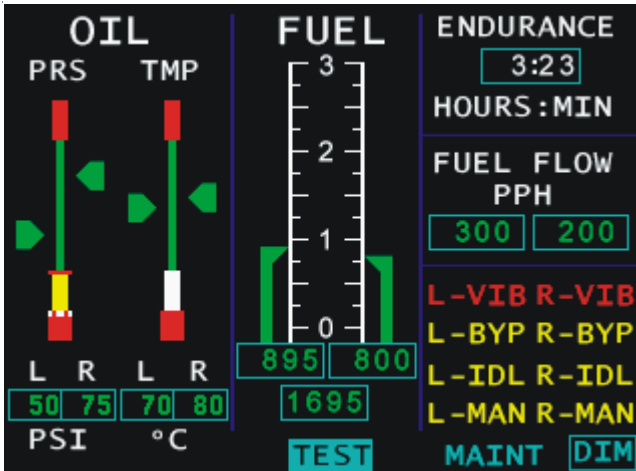

Fig. 1-5. Secondary Engine Display Unit (EDU)

The information presented in the Secondary page includes:

- **FUEL FLOW** - Fuel Flow in Pounds-Per-Hour (**PPH**).
- **OIL °C** - Oil Temperature in degrees Celsius.
- **OIL PSI** - Oil Pressure in Pounds-per-Square Inch (**PSI**).
- **TOTAL FUEL** - The total fuel remaining in the left and right fuel tanks in pounds.
- **FUEL** - The fuel remaining in the left or right tank groups in pounds.
- **ENDURANCE** - Run time based on remaining fuel and current fuel flow rate.
- **MAINT** - The **MAINT** indicator is illuminated when a maintenance action is required.
- **L/R-VIB** - Indicates left or right engine vibration limits exceeded (N/A for Eagle II, optional on other modified aircraft).
- **L/R-BYP** - Indicates left or right engine fuel filter impending bypass. (N/A for Eagle II, optional on other modified aircraft).
- **L/R-IDL** - Indicates left or right engine in ground idle mode (FJ44 only).
- **L/R-MAN** - Indicates that the left or right **ECU** is in manual mode (FJ44 only).

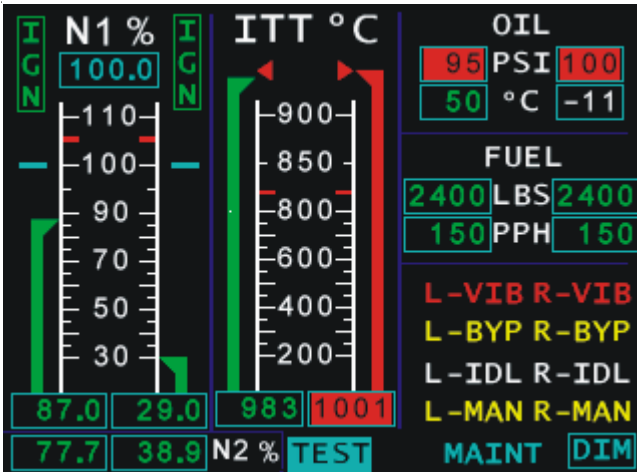

Fig. 1-6. Reversionary Display

The information presented in the Reversionary page includes:

- **ITT** - Inter Turbine Temperature in degrees Celsius.
- **N1%** - The **N1** rotational rate, expressed as a percentage of maximum.
- **N2%** - The **N2** rotational rate, expressed as a percentage of maximum.
- **IGN** - Indicates that the left or right engine igniter is on. (N/A for Eagle II, optional on other modified aircraft).
- **OIL °C** - Oil Temperature in degrees Celsius.
- **OIL PSI** - Oil Pressure in Pounds-per-square Inch (**PSI**)
- **FUEL LBS** - The fuel remaining in the left or right tank groups in pounds.
- **FUEL PPH** - Fuel Flow in Pounds-per-Hour (**PPH**).
- **MAINT** - The **MAINT** indicator is illuminated when a maintenance action is required.
- **L/R-VIB** - Indicates left or right engine vibration limits exceeded (N/A for Eagle II, optional on other modified aircraft).
- **L/R-BYP** - Indicates left or right engine fuel filter impending bypass. (N/A for Eagle II, optional on other modified aircraft).
- **L/R-IDL** - Indicates left or right engine in ground idle mode (FJ44 only).
- **L/R-MAN** - Indicates that the left or right **ECU** is in manual mode (FJ44 only).
- **DIM/N1** - Indicates the current mode of the **SET** rotary knob.

MAGIC® EIDS POH FOR CESSNA CITATION

1.1.2 Data Acquisition Unit (DAU)

The **DAU** converts analog data from the sensors to serial digital data, which is then sent to the **EDUs**. The **DAU** is remote mounted and does not have any controls.

1.2 Product Support

In the United States Call: 800–USA–STEC or 940–325–9406.

NOTE: The **MAGIC® EIDS POH**, 87194, applies to:

EDU P/N: 84–142–1 or Equivalent

DAU P/N: 85–267–1 or Equivalent

SECTION 2

ENGINE DISPLAY UNIT

Table of Contents

- 2.0 Engine Display Unit Operation.....2-3**
 - 2.1 Initialization Pages.....2-3**
 - 2.2 Operational Controls.....2-3**
 - 2.2.1 MAINT Pushbutton.....2-3
 - 2.2.2 Set Knob Pushbutton.....2-4
 - 2.2.3 Set Knob.....2-4
 - 2.3 Modes.....2-4**
 - 2.3.1 Exceedance Data Display.....2-5
 - 2.3.2 Mission Operational Primary Mode.....2-6
 - 2.3.3 Mission Operational Secondary Mode.....2-7
 - 2.3.4 Reversionary Mode.....2-8
 - 2.3.5 Test Mode.....2-9
 - 2.3.5.1 Initialization – Test Mode2-9
 - 2.3.5.2 Exceedance Data – Test Mode.....2-9
 - 2.3.5.3 Primary Display – Test Mode.....2-9
 - 2.3.5.4 Secondary Display – Test Mode.....2-9
 - 2.3.5.5 Reversionary Display – Test Mode.....2-9
 - 2.3.5.6 **EDU** Data Page2-11
 - 2.3.5.7 **FQP** Data Page.....2-12
 - 2.3.5.8 **DAU** Data Page.....2-13
 - 2.4 Annunciations.....2-14**

2.0 Engine Display Unit Operation

The Engine Display Unit is hereafter also referred to as **EDU** or unit.

2.1 Initialization Pages

The Initialization Pages are shown in Fig. 2-1. They are displayed only during the first 5 seconds following power-up. Primary display cycles, however, Secondary stays until **PAGE** button is depressed.

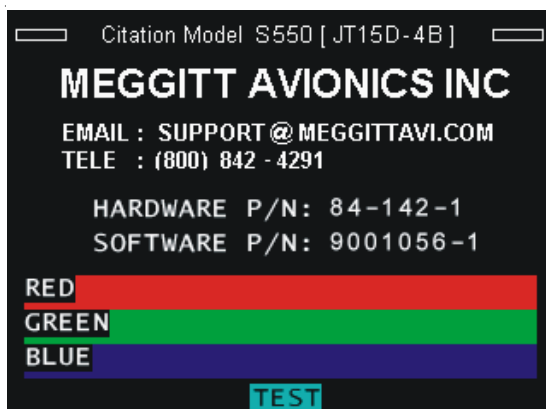

Fig. 2-1. Initialization Pages

- Line 1 - Aircraft Type and Engine Type.
- Line 5&6 - Part Numbers (numbers shown in Fig 2-1 for reference only).

2.2 Operator Controls

There are 3 operator controls on the **EDU**: the “**PAGE**” pushbutton, the “**MAINT**” pushbutton, and the “**SET**” Rotary Knob with integral pushbutton, all located on the bottom of the bezel.

2.2.1 MAINT Pushbutton

Activation of the **MAINT** pushbutton during either Mission Operational or Test Mode will display the Exceedance Data Page. The **EDU** will return to the previously selected page immediately after the **MAINT** pushbutton is released.

2.2.2 SET Knob Pushbutton

Activation of the **SET** Knob Pushbutton will cycle between "**N1**" and "**DIM**".

2.2.3 SET Knob

The **SET** rotary knob can be set to **N1** pre-select value and to adjust the brightness of the display. The current function of the knob is annunciated in the lower right hand corner of the display as "**N1**" or "**DIM**". Pushing and releasing the **SET** knob will toggle between the functions when either the Primary or Reversionary screens are displayed. On all other screens, the knob will function only as a dimming control as there will be no **N1** pre-select value to set.

In the "**N1**" mode, clockwise rotation of the **SET** knob will increase the **N1** pre-select value in increments of 0.1% RPM. Counter-clockwise rotation of the **SET** knob will decrease the **N1** pre-select value in decrements of 0.1% RPM.

In the "**DIM**" mode, the clockwise rotation of the **SET** knob will increase the brightness of the display while counter-clockwise rotation will dim the display.

2.3 Modes

The **EDU** has two operating modes:

- Mission Operational Mode
- Test Mode

NOTE: The operating ranges of display parameters are contained in Appendices '**D**' and '**E**'.

2.3.1 Exceedance Data Display

The Exceedance Data Display can be accessed anytime during Mission Operational Mode or Test Mode by activation of the **MAINT** button.

EXCEEDANCE DATA					
DATE	TIME	PARAM	PEAK		DUR
11/15	0:59	L ITT	1023	°F	59:59
11/15	0:03	R OIL P	1095	PSI	0:01
01/17	0:00	- OIL T	5461	°C	1:42
10/07	0:39	L N1	16383	RPM	15:11
06/21	0:51	- N2	16383	RPM	0:01
-	-	-	-	-	-
-	-	-	-	-	-
-	-	-	-	-	-
DISPLAY:		08000000	MAINT:		0011
					MAINT DIM

Fig 2-2. Exceedance Data Display

The information provided by the Exceedance Data Page includes:

- **DATE** - The date of the exceedance event.
- **TIME** - The **GMT** time of the exceedance event .
- **PARAM** - Identifies the physical measurement which caused the exceedance event.
- **PEAK** - The maximum value attained by the parameter during the exceedance event.
- **DUR** - The duration (**DUR**) is the elapsed time of the exceedance event.

NOTE: If there is no **GPS** input available at the time of the exceedance event, then the **DATE** field will display the default of " _ _ _ _ ".

NOTE: The time display is based upon a 24 hour clock; i.e. 1 PM is displayed as 13:00. If a **GPS** input is not available, the **TIME** field will be blank.

2.3.2 Mission Operational Primary Mode

Only the primary EDU operates in the Primary Mode (see Fig. 2-4). This is the default mode that the unit enters after the first 5 seconds following power-up. In this mode, the Page Button may be used to cycle through the unit's various pages. These are the Primary Page and Reversionary Page. A flowchart of these pages' sequencing is shown in Fig. 2-3.

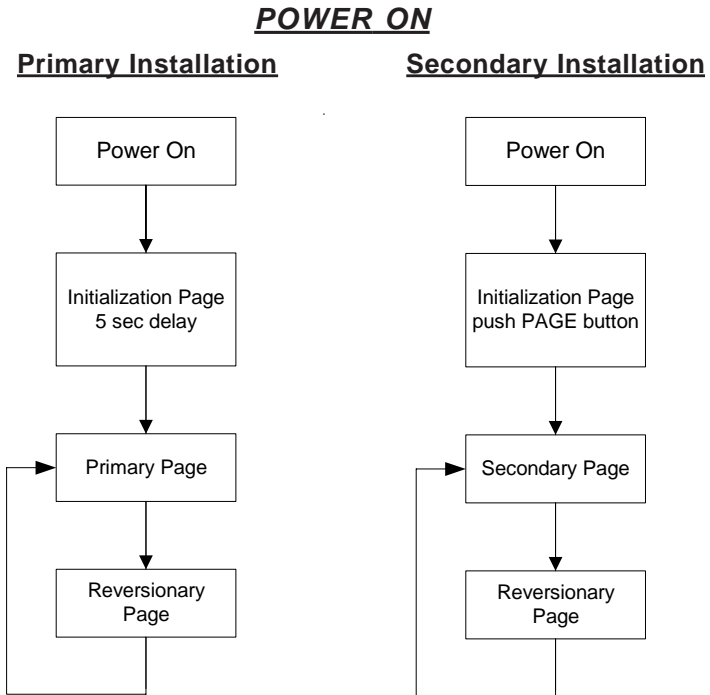

Fig. 2-3. Flowchart of Page Sequencing - Mission Operational Mode

2.3.3 Mission Operational Secondary Mode

Only the secondary **EDU** operates in the Secondary Mode (see Fig. 2-5). The Page Button is used to cycle through the unit's various pages. These are the Secondary Page and Reversionary Page. A flow chart of this page sequencing is shown in Fig. 2-3.

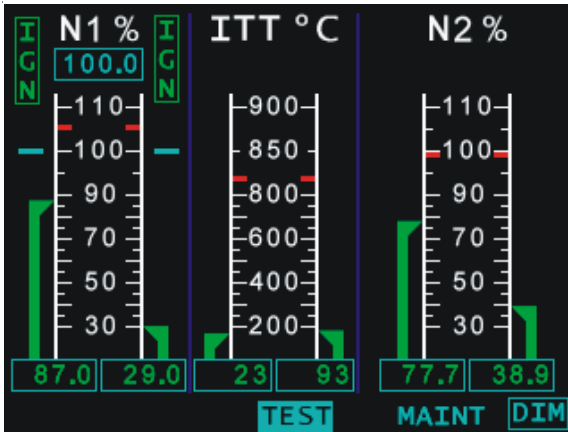

Fig. 2-4. Primary Engine Display Unit (EDU)

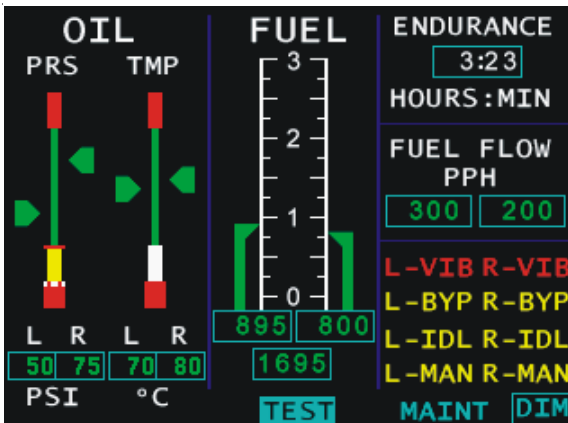

Fig. 2-5. Secondary Engine Display Unit (EDU)

2.3.4 Reversionary Mode

The Reversionary display is used to display all engine information on a single screen. The pilot displays the Reversionary page from either the Primary or Secondary screen by depressing the **PAGE** switch. The Reversionary display is depicted in Fig. 2-6.

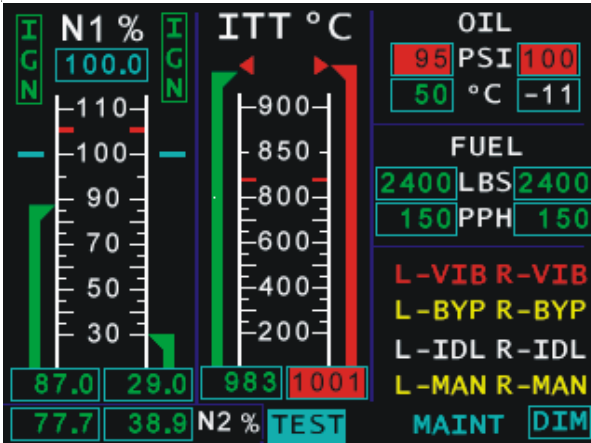

Fig. 2-6. Reversionary Display

2.3.5 Test Mode

Test Mode is designed to be used during test and fault diagnostics of the **EDU** and is entered by depressing and holding the **MAINT** pushbutton during **EDU** power up, until the Initialization Page is displayed. Note that the **EDU** will remain in Test Mode until power is turned off. The display pages that are available in Test Mode are identified in Table 2-1. The test data pages are displayed in sequence by depressing the **PAGE** switch.

NOTE: Test Mode is intended for ground maintenance use only.

Sequence #	Display Page Name	Comment
0	Initialization Page	
1	Exceedance Data – Test Mode	“Test Mode” added to normal exceedance display
2	Primary -Test Mode	“Test Mode” added to normal primary display
3	Secondary – Test Mode	“Test Mode” added to normal secondary display
4	Reversionary – Test Mode	“Test Mode” added to normal reversionary display
5	EDU Data Page	
6	FQP Data Page	
7	DAU Data Page	

Table 2-1 Test Mode Pages

2.3.5.1 Initialization – Test Mode Page Layout

The Initialization - Test Mode display page is identical to Figure 2-1 with the addition of "**TEST MODE**" indication.

2.3.5.2 Exceedance Data – Test Mode Page Layout

The Exceedance - Test Mode display page is identical to Figure 2-2 with the addition of a "**TEST MODE**" indication.

2.3.5.3 Primary Display – Test Mode Page

The Primary - Test Mode display page is identical to Figure 2-4 with the addition of a "**TEST MODE**" indication.

2.3.5.4 Secondary Display-Test Mode Page

The Secondary- Test Mode display page is identical to Figure 2-5 with the addition of a "**TEST MODE**" indication.

2.3.5.5 Reversionary Display-Test Mode Page

The Reversionary-Test Mode display page is identical to Figure 2-6 with the addition of a "**TEST MODE**" indication.

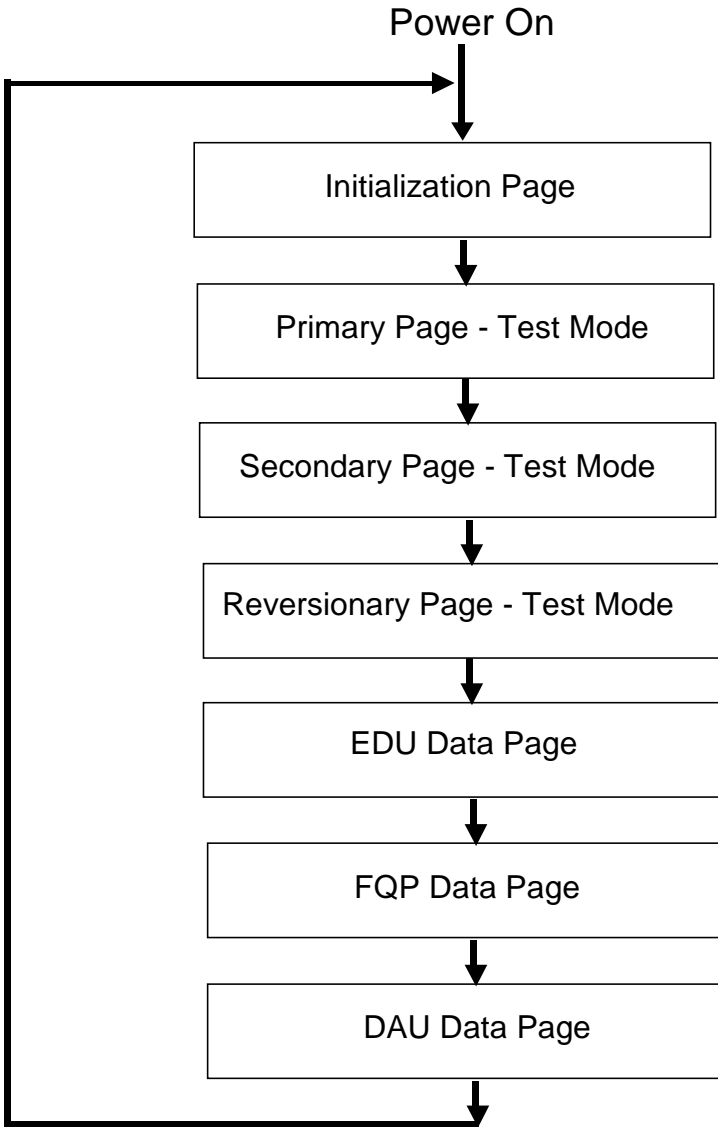

Fig. 2-7. PAGE Pushbutton Operation - Test Mode

2.3.5.6 EDU Data Page

The **EDU** Data Page contains the information depicted in Fig. 2-8.

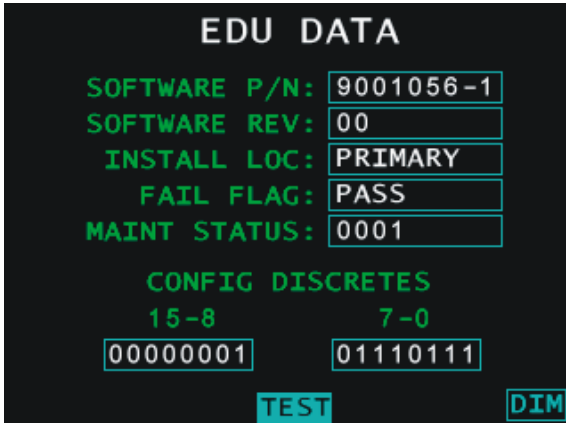

Fig. 2-8. EDU Data Page

The information provided by the **EDU** Data Page includes:

- **SOFTWARE P/N** - Identity of the **EDU** computer program which is being executed.
- **SOFTWARE REV** - The revision level of the **EDU** computer program.
- **INSTALL LOC** - The position of this **EDU** in the aircraft, i.e., **PRIMARY** position (pilot location) or **SECONDARY** position (co-pilot location).
- **FAIL FLAG** - The result of the **EDU** built in test.
- **MAINT STATUS** - The result of the **EDU** built in test.
- **CONFIGDISCRETES** - The binary values assigned to the configuration discrete inputs.

Note: The value of configuration discrete 15 is the first character on the left of the display; the value of configuration discrete 0 is the right most character.

2.3.5.7 FQP Data Page

This **FQP** Data Page, as depicted in Fig. 2-9., displays the current **FQP** operating mode and software configuration as received over the dual **FQP** serial data bus and is also used to facilitate on-aircraft fuel quantity calibration of the **DAU**.

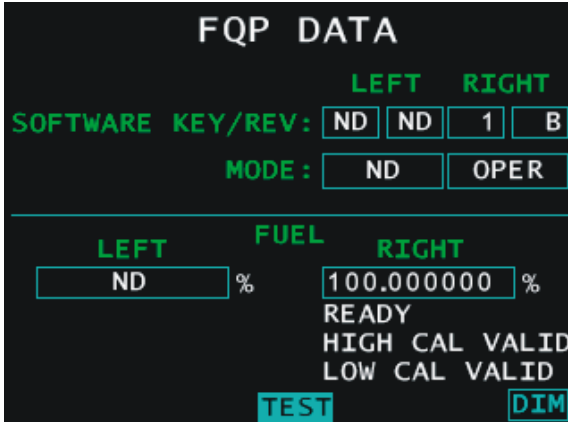

Fig. 2-9. FQP Data Page

The information provided by the **FQP** Data Page includes:

- **SOFTWARE KEY/REV** - Identity of the **FQP** computer program which is being executed on the left and right channels.
- **MODE** - The current mode of the left or right channel **FQP**.
- **FUEL** - Used for on aircraft **FQP** calibration. Reference the **DAU** Installation and Operating Instructions for details.

2.3.5.8 DAU Data Page Layout

This **DAU** Data Page layout, as depicted in Fig. 2-10., displays the **DAU** configuration information. This page displays configuration and status data for the **DAU's** connected to **EDU** channels **A** and **B** as well as for the **ASI's** connected to **EDU** channels **C** and **D**.

DAU DATA						
CH	KEY	REV	MODE	EQ ID	FAIL	
A	BD1	32	A TEST	800	PASS	
B	BD1	32	A TEST	800	PASS	
CONFIG DISCRETES					04000	
ASI DATA						
C	BD2	1	B OPER	800	FAIL	
D	BD1	2	C TEST	801	PASS	
CONFIG DISCRETES					04001	
			TEST	DIM		

Fig. 2-10. DAU Data Page 2

Note: The hardware and software part numbers shown are for example purposes only.

The information provided by the **DAU** Data Page includes:

- **KEY** - Identifies the computer program being executed.
- **REV** - Identifies the revision level of the computer program.
- **MODE** - Identifies the current mode of the **DAU** or **ASI** to which the **EDU** channel is connected.
- **EQ ID** - Identifies the Equipment ID of the **DAU** or **ASI** to which the **EDU** channel is connected.
- **FAIL** - Identifies the Built In Test result of the **DAU** or **ASI** to which the **EDU** channel is connected.
- **CONFIG** - Identifies the configuration discrete settings of the **DAU** or **ASI** to which the **EDU** channel is connected.

Note: A display of "ND" for any portion of the display indicates that there is a communications problem between the **EDU** and the **DAU/ASI**. This can be the result of a faulty **EDU**, faulty **DAU**, or faulty aircraft wiring. Maintenance action is required.

2.4 Annunciations

The **EDU** provides for a set of flag indications, as listed in Table 2-2.

Flag Name	Flag Description
MAINT	A fault has been uncovered by either the DAU or EDU built in test which requires a maintenance action. See Appendix B for a list of maintenance codes.
FAIL FLAG (EDU Data Page)	Indicates if the MAINT flag illumination was the result of the EDU being observed. A "FAIL" indicates that this unit is faulty.
FAIL FLAG (DAU Data Page)	Indicates if the MAINT flag illumination was the result of a failed DAU channel. A "FAIL" indicates that the channel is faulty.
IGN	Indicates igniter of the left or right engine is on.
L-BYP or R-BYP	Indicates a left or right engine fuel filter impending bypass
L- VIB or R-VIB	Indicates left or right engine vibration limits exceeded.
L-IDL or R-IDL	Indicates left or right engine in ground idle mode (FJ44 installations only).
L-MAN or R-MAN	Indicates that the left or right Engine Control Unit (ECU) is in manual mode (FJ44 installations only).

Table 2-2. Annunciations

NOTE: There are two types of fault indications that occur on either the Primary or Secondary **EDU** when data is faulty or missing.

1. Data Acquisition Unit or Fuel Quantity Parameter data on **EDUs** indicates "----". This signifies that invalid data is being received.
 2. Data Acquisition Unit or Fuel Quantity Parameter data on **EDUs** indicates "**ND**". This signifies that no data is being received.
- * Oil Pressure trend arrows are displayed when an increasing or decreasing value of more than 1% per second is detected.

SECTION 3

PRE-FLIGHT PROCEDURES

Table of Contents

3.0	Pre-Flight Test Procedures.....	3-3
3.1	Power-Up.....	3-3

3.0 Pre-Flight Procedures

3.1 Power-Up

1. Set the Battery Switch to the **ON** position.

NOTE: During sequencing of Primary / Secondary **EDU** displays, verify all applicable engine parameters are displayed, that there are **NO** "----" or "**ND**" displayed for any parameter, and that there are **NO MAINT** Flags.

Verify on Primary EDU:

1. The Initialization Page is displayed for 5 seconds, after which the Primary Page is displayed.
2. Press the Page Button on the Primary **EDU**. The Reversionary Page is displayed.

NOTE: If a **MAINT** flag appears, refer to Appendix '**F**' for Code details.

3. Press the Page button. The Primary **EDU** Page appears.

Verify on Secondary EDU:

1. That the Initialization Page and correct A/C is displayed.
2. Press the Page button on the Secondary **EDU** to display the Secondary page.
3. Press the Page Button on the Secondary **EDU**. The Reversionary Page is displayed.
4. Press the Page button. The Secondary Page is displayed.
5. Reset fuel if required.

NOTE: If **MAINT** Flags appear, refer to Appendix '**F**' for Code details.

Page Intentionally Blank

SECTION 4 APPENDICES

Page Intentionally Blank

APPENDIX A: Colors of Displayed Symbols**Graphical Symbols:**

<u>Condition</u>	<u>Color</u>
Transitional/Normal	White
Normal	Green
Caution	Yellow
Warning	Red

Digital Symbols:

<u>Condition</u>	<u>Color</u>
Normal	White on Black Background
Caution	Black on Yellow Background
Warning	Black on Red Background

APPENDIX B: Specifications**Engine Display Unit (EDU)**

Operating Input Voltage	+10 VDC	to	+32 VDC
Operating Power (Maximum)	28 W	@	+28 VDC
Operating Temperature	-40 °C	to	+70 °C
Storage Temperature	-55 °C	to	+85 °C
Weight (Maximum)	4.0 lb.		
Length	6.375 in.		
Width	5.340 in.		
Height	4.490 in.		

Data Acquisition Unit (DAU)

Operating Input Voltage	+10 VDC	to	+32 VDC
Operating Power (Maximum)	20 W	@	+28 VDC
Operating Temperature	-40 °C	to	+70 °C
Storage Temperature	-65 °C	to	+85 °C
Weight (Maximum)	5.5 lb.		
Length	9.400 in.		

APPENDIX B: Operating Ranges of Display Parameters (cont'd)

	Engine State		560/552	S550	550/551	500/501	Eagle II
N1	All	Units	%RPM	%RPM	%RPM	%RPM	%RPM
		Range	≥0 to ≤110	≥0 to ≤110	≥0 to ≤110	≥0 to ≤110	≥0 to ≤110
		Transitional Range	≥0 to <25	≥0 to <25	≥0 to <25	≥0 to <25	≥0 to <24.5
		Normal	≥25 to <104	≥25 to <106	≥25 to <104	≥25 to <*	≥24.5 to <105.2
		Red Line	104	106	104	*	105.2
		Warning	≥104 to ≤110	≥106 to ≤110	≥104 to ≤110	≥* to ≤110	≥105.2 to ≤110
N2	All	Unit	%RPM	%RPM	%RPM	%RPM	%RPM
		Range	≥0 to ≤110	≥0 to ≤110	≥0 to ≤110	≥0 to ≤110	≥0 to ≤110
		Transitional Range	≥0 to <46	≥0 to <49	≥0 to <46	≥0 to <46	≥0 to <48
		Normal	≥46 to <96	≥49 to <97	≥46 to <96	≥46 to <95	≥48 to <98.8
		Red Line	96	97	96	95	98.8
		Warning	≥96 to ≤110	≥97 to ≤110	≥96 to ≤110	≥95 to ≤110	≥98.8 to ≤110

* 99% for the -1 engine; 102.1% for the -1A engine; 103.4% for the -1B engine

	Engine State		560/552	S550	550/551	500/501 Standard Fuel Cells	500/501 Extended Fuel Cells	Eagle II
Fuel Quantity (Left and Right)	All	Units	LB	LB	LB	LB	LB	LB
		Range	≥0 to ≤3000	≥0 to ≤3000	≥0 to ≤2450	≥0 to ≤2000	≥0 to ≤2400	≥0 to ≤2400
		Normal	≥0 to ≤3000	≥0 to ≤3000	≥0 to ≤2450	≥0 to ≤2000	≥0 to ≤2400	≥0 to ≤2400
		Caution	N/A	N/A	N/A	N/A	N/A	N/A
Fuel Quantity (Total)	All	Units	LB	LB	LB	LB	LB	LB
		Range	≥0 to ≤6000	≥0 to ≤6000	≥0 to ≤4900	≥0 to ≤4000	≥0 to ≤4800	≥0 to ≤4800
		Normal	>300 to ≤6000	>300 to ≤6000	>300 to ≤4900	>300 to ≤4000	>300 to ≤4800	>300 to ≤4800
		Caution	≤300	≤300	≤300	≤300	≤300	≤300

APPENDIX B: Operating Ranges of Display Parameters (cont'd)

	Engine State		560/552	S550	550/551	500/501	Eagle II
ITT	All	Unit	°C	°C	°C	°C	°C
		Range	≥-55 to ≤1000	≥-55 to ≤1000	≥-55 to ≤1000	≥-55 to ≤1000	≥-55 to ≤1100
		Transitional Range	≥-55 to <150	≥-55 to <150	≥-55 to <150	≥-55 to <150	≥-55 to <200
	Continuous	Normal	≥150 to <680	≥150 to <690	≥150 to <680	≥150 to <680	≥200 to <805
		Caution	≥680 to <700	≥690 to <710	≥680 to <700	≥680 to <700	≥805 to <820
		Red Line	700	710	700	700	820
		Warning	≥700 to ≤1000	≥710 to ≤1000	≥700 to ≤1000	≥700 to ≤1000	≥820 to ≤1100
	Idle	Normal	≥150 to <580	≥150 to <580	≥150 to <580	≥150 to <580	≥200 to <805
		Caution	≥580 to <700	≥580 to <710	≥580 to <700	≥580 to <700	≥805 to <820
		Red Line	700	710	700	700	820
		Warning	≥700 to ≤1000	≥710 to ≤1000	≥700 to ≤1000	≥700 to ≤1000	≥820 to ≤1100
	Start	Normal	≥150 to <680	≥150 to <500	≥150 to <500	≥150 to <680	≥200 to <820
		Caution	≥680 to <700	≥500 to <710	≥500 to <700	≥680 to <700	≥820 to <1000
		Red Line & Red Triangle	700	710	700	700	820; Red Triangle at 1000
		Warning	≥700 to ≤1000	≥710 to ≤1000	≥700 to ≤1000	≥700 to ≤1000	≥1000 to ≤1100

APPENDIX B: Operating Ranges of Display Parameters (cont'd)

	Engine State		560/552	S550	550/551	500/501	Eagle II
OIL PRESS	All	Unit	psig	psig	psig	psig	psig
		Range	≥0 TO ≤100	≥0 TO ≤100	≥0 TO ≤100	≥0 TO ≤100	≥0 TO ≤100
		Normal	>60 to <83	>70 to <85	>70 to <85	>65 to <80	>35 to <90
		Caution	>40 to ≤60	>35 to ≤70	>35 to ≤70	>35 to ≤65	>23 to ≤35
		Red Line	40 & 83	35 & 85	35 & 85	35 & 80	35 & 90
		Red/White Striped Line	N/A	N/A	N/A	N/A	23
		Red Triangle*	95	95	95	95	100
		Warning	≥0 to ≤40 ≥83 to ≤100	≥0 to ≤35 ≥85 to ≤100	≥0 to ≤35 ≥85 to ≤100	≥0 to ≤35 ≥80 to ≤100	≥0 to ≤23 ≥90 to ≤100
FUEL FLOW	All	Unit	pph	pph	pph	pph	pph
		Range	≥0 to ≤1400	≥0 to ≤1400	≥0 to ≤1400	≥0 to ≤1400	≥0 to ≤1900
		Transitional	N/A	N/A	N/A	N/A	≥0 to <85 >1800 to ≤1900
		Normal	≥0 to ≤1400	≥0 to ≤1400	≥0 to ≤1400	≥0 to ≤1400	≥85 to ≤1800
		Caution	N/A	N/A	N/A	N/A	N/A
		Red Line	N/A	N/A	N/A	N/A	N/A
		Warning	N/A	N/A	N/A	N/A	N/A
OIL TEMP.	All	Unit	°C	°C	°C	°C	°C
		Range	≥-55 to ≤150	≥-55 to ≤150	≥-55 to ≤150	≥-55 to ≤150	≥-55 to ≤150
		Normal	>10 to <121	>10 to <121	>10 to <121	>10 to <121	>10 to <135
		Transitional	>-40 to ≤10	>-40 to ≤10	>-40 to ≤10	>-40 to ≤10	>-40 to ≤10
		Red Line	-40 121	-40 121	-40 121	-40 121	-40 135
		Warning	≥121 to ≤150 ≥-55 to ≤-40	≥121 to ≤150 ≥-55 to ≤-40	≥121 to ≤150 ≥-55 to ≤-40	≥121 to ≤150 ≥-55 to ≤-40	≥135 to ≤150 ≥-55 to ≤-40

* Red triangle displayed during Engine Start only

APPENDIX C: Troubleshooting Guide

Symptom	Possible Cause	Action
No display visible at power up	+28 VDC power missing	Check wiring and bus voltage
	+28 VDC Return missing	Check wiring
	Failed EDU	Replace EDU
Display does not dim	28 VDC lighting bus not connected or not functional	Check wiring and 28 VDC lighting bus
Display page does not change when PAGE button is pressed	Failed EDU	Replace EDU
Exceedance page is not displayed when MAINT button is pressed	Failed EDU	Replace EDU
Rotation of the SET knob does not result in a change to the N1 pre-select value when the knob is set to N1	Failed EDU	Replace EDU
Pushing the SET knob does not toggle between N1 and DIM when the Primary page is displayed	Failed EDU	Replace EDU
SYSTEM STATUS on Exceedance page is indicated as FAIL	Failed EDU or DAU/ASI	Check EDU and DAU DATA Pages
FAIL FLAG on EDU DATA page is indicated as FAIL	Failed EDU	Replace EDU
Installation Location not correctly indicated	Configuration Discrete 0-7 not wired properly	Check wiring
Switch inputs not functional	Switch inputs (Event Discretes) not wired properly	Check wiring
Output advisories not functional	Output Discrete 0 – 5 not wired properly	Check wiring
DAU or ASI/ECU on DAU DATA page indicated as "----". This indicates that invalid data is being received	ARINC IN A and B lines are backwards.	Check wiring
	Failed DAU or ASI/ECU	Replace DAU or ASI/ECU
DAU or ASI/ECU data on DAU DATA page indicated as "ND". This indicates that no data is being received	ARINC inputs not connected	Check wiring
	Failed DAU or ASI/ECU	Replace DAU or ASI/ECU
DAU or ASI FAIL FLAG indicated as FAIL	Failed DAU or ASI	Replace DAU or ASI
	Faulty Engine Sensor or Wiring	Check sensors and wiring
FQP data on FQP DATA page indicated as "----". This indicates that invalid data is being received	RS422 RECEIVE A and B lines are backwards	Check wiring
	Failed DAU	Replace DAU
FQP data on FQP DATA page indicated as "ND". This indicates that no data is being received	RS422 inputs not connected	Check wiring
	Failed DAU	Replace DAU

APPENDIX C: Troubleshooting Guide (cont'd)**MAINT Status Codes:**

CODE	DESCRIPTION	ACTION
PASS	No faults found	None
01	No data is being received for one or more parameters	Check to ensure that all parameters are being received on all input channels
02	General DAU failure	Replace DAU
04	The operating mode of the EDU and Primary DAU channel do not match.	Reset units such that both are in the same mode (Mission Operational or Test)
08	The operating mode of the EDU and Secondary DAU channel do not match.	Reset units such that both are in the same mode (Mission Operational or Test)
10	General EDU failure	Replace EDU
20	Data received from DAU Channel 1, DAU Channel 2 and the tertiary source (ASI) do not match within an acceptable tolerance	Check accuracy of DAU and ASI
40	EDU and DAU configuration strapping does not match	Check configuration strapping of EDU and DAU

Display Status Codes:

CODE	DESCRIPTION	ACTION
PASS	NO FAULT	None
00000001	RAM_PROGRAM_CHECKSUM_FAULT	Replace EDU
00000002	RAM_CONFIG_CHECKSUM_FAULT	Replace EDU
00000004	DUART1_INIT_FAULT	Replace EDU
00000008	DUART2_INIT_FAULT	Replace EDU
00000010	ARINC_INIT_FAULT	Replace EDU
00000020	ARINC_LOOPBACK_FAULT	Replace EDU
00000040	DUART1_LOOPBACK_FAULT	Replace EDU
00000080	DUART2_LOOPBACK_FAULT	Replace EDU
00000100	TIMER_COUNT_COMPARISON_FAULT	Replace EDU
00000200	ARINC_RCV1_Q_OVFLW_FAULT	Replace EDU
00000400	ARINC_RCV2_Q_OVFLW_FAULT	Replace EDU
00000800	DUART1_RCVA_Q_OVFLW_FAULT	Replace EDU

APPENDIX C: Troubleshooting Guide (cont'd)

00001000	DUART1_TXA_Q_OVFLW_FAULT	Replace EDU
00002000	DUART2_RCVA_Q_OVFLW_FAULT	Replace EDU
00004000	DUART2_RCVB_Q_OVFLW_FAULT	Replace EDU
00008000	NOT USED	None
00010000	NOT USED	None
00020000	NOT USED	None
00040000	NOT USED	None
00080000	NOT USED	None
00100000	NOT USED	None
00200000	ADC_INIT_FAULT	Replace EDU
00400000	WATCHDOG_FAULT	Replace EDU
00800000	VIDEO_WATCHDOG_FAULT	Replace EDU
01000000	ADC_NOT_READY_FAULT	Replace EDU
02000000	ADC_REFERENCE_LOW_FAULT	Replace EDU
04000000	ADC_REFERENCE_MID_FAULT	Replace EDU
08000000	INVALID_ARINC_FORMAT_FAULT	Replace EDU
10000000	LAMP_POWER_ON_FAULT	Replace EDU
20000000	LAMP_BRIGHTNESS_FAULT	Replace EDU
40000000	NOT USED	None
80000000	NOT USED	None

Page Intentionally Blank

SECTION 5 GLOSSARY

Page Intentionally Blank

GLOSSARY

<u>Term</u>	<u>Meaning</u>
ADAHRS	Air Data Attitude Heading Reference System
AFM	Aircraft Flight Manual
AFMS	Aircraft Flight Manual Supplement
ASI	Auxiliary Sensor Interface
DAU	Data Acquisition Unit
ECU	Engine Control Unit
EDU	Engine Display Unit
EMI	Electro Magnetic Interference
ESD	Electro Magnetic Device
FAA	Federal Aviation Administration
FAR	Federal Aviation Requirement
FQP	Fuel Quantity Processor
GPS	Global Positioning System
H/W	Hardware
ID	Identification
LRU	Line Replaceable Unit
MAv	Meggitt Avionics Inc.
MTBF	Mean Time Between Failures
NCD	Non Computed Data
ND	Navigation Display
PFD	Primary Flight Display
PROM	Programmable Read Only Memory
PWM	Pulse Width Modulation
RAM	Random Access Memory
SRS	System Requirements Specification
SRU	Shop Replaceable Unit
SSM	Sign Status Matrix
TBD	To Be Defined
UUT	Unit Under Test

Page Intentionally Blank

S-TEC

One S-TEC Way • Municipal Airport
Mineral Wells, Texas 76067-9236 USA
Telephone: (940) 325-9406; FAX: (940) 325-3904
1-800-USA-STECH
www.magic.aero
www.s-tec.com

Information in this document is subject to change without notice. ©2004 S-TEC. All rights reserved. Printed in the United States of America. S-TEC and the S-TEC logo are registered trademarks of S-TEC.

Notice: You must contact S-TEC Customer Support at 800-872-7832 for a Return Material Authorization (RMA) number prior to the return of any component for any reason.

P/N: 87194
Date: May 24, 2004
Printed in USA